

A Comparative Analysis of LS and MMSE Channel Estimation Techniques for MIMO-OFDM System

Akash Kumar Shrivastava
Assistant Professor/ ETC
SSEC, (SSTC), Bhilai, Chattisgarh , India

Abstract

The objective of this study is up channel estimation accuracy in OFDM system as a result of channel state info is needed for detection at receiver and its accuracy affects the performance of system and it's essential to improve the channel estimation for a lot of reliable communications. OFDM system was chosen during this study because it's been wide used nowadays owing to its high knowledge rate, data rate and its adequate performance in frequency selective attenuation channels. The pilots were inserted among subcarriers in transmitter with distances emerged of sampling theory then Least sq. (LS) technique & minimum mean-square error (MMSE) was chosen for initial channel estimation in pilots at receiver, mistreatment applicable projected receiver, that has straight forward and usable structure, then channel state info was calculable by linear interpolator in information subcarriers, that uses 2 adjacent channel estimation in pilots to calculate channel in another subcarriers and associate degree LMS repetitive algorithmic rule, as well as a feedback of output is another to system. This algorithmic rule uses the channel estimation of last iteration in current estimation. Adding a LMS repetitive algorithmic rule to system, improves the channel estimation performance. Simulation results established the acceptable BER performance of repetitive channel estimation algorithm, that is closed to the best channel. The low complexity projected receiver as well as LMS algorithmic rule, has a higher potency than typical methods (without channel estimation & LMMSE) and it will add lower quantity of SNRs.

Keywords: Least Square (LS), Minimum Mean-Square Error (MMSE). OFDM, LS Channel Estimation, LMMSE Channel Estimation.

I. INTRODUCTION

It is a widely known undeniable fact that the number of knowledge transported over communication systems grows speedily. Not solely the file sizes increase, however additionally massive bandwidth-required applications like video on demand and video conferencing need increasing knowledge rates to transfer the knowledge during a affordable quantity of your time or to ascertain time period connections. To support this sort of services, broadband communication systems square measure needed. Large-scale penetration of wireless systems into our daily lives would force important reductions in price and will increase in bit rate and/or system capability. Recent data theoretical studies have unconcealed that the multipath wireless channel is capable of giant capacities, only if multipath scattering is sufficiently made and is correctly exploited through the utilization of the spatial dimension . applicable solutions for exploiting the multipath properly, might be supported new techniques that recently appeared in literature, that square measure supported Multiple Input Multiple Output (MIMO) technology. Basically, these techniques transmit totally completely different knowledge streams on different transmit antennas at the same time. By coming up with Associate in Nursing applicable process design to handle these parallel streams of information, the information rate and/or the signal/noise ratio (SNR) performance may be enlarged. Multiple Input Multiple Output (MIMO) systems square measure usually combined with a spectrally economical transmission technique referred to as Orthogonal Frequency Division Multiplexing (OFDM) to avoid put down image Interference (ISI).

OFDM is turning into wide applied in wireless communications systems attributable to its high rate transmission capability with high information measure potency and its strength with relation to multi-path attenuation and delay. it's been used in digital audio broadcasting (DAB) systems, digital video broadcasting (DVB) systems, digital telephone line (DSL) standards, and wireless LAN standards like the American IEEE® Std. 802.11™ (WiFi) and its European equivalent HIPRLAN/2.

There are 2 main issues in coming up with channel estimators for wireless OFDM systems. the primary drawback is that the arrangement of pilot info, wherever pilot means that the reference signal utilized by each transmitters and receivers. The second drawback is that the style of associate computer with each low quality and smart channel trailing ability. the 2 issues are interconnected. In general, the weakening channel of OFDM systems will be viewed as a two-dimensional (2D) signal (time and frequency).

II. SYSTEM DESCRIPTION

The basic set up underlying OFDM systems is that the division of the out there frequency spectrum into several subcarriers. to get a high spectral efficiency, the frequency responses of the subcarriers are overlapping and orthogonal, hence the name OFDM. This orthogonality is totally maintained with a small low value in a very loss in SNR, but the signal passes through a time dispersive attenuation channel, by introducing a cyclic prefix (CP). A diagram of a baseband OFDM system is shown in Figure I. The binary information is initial sorted, coded, and mapped in step with the modulation throughout a “signal plotter.” once the guard band is inserted, academic degree N-point inverse discrete-time Fourier transform (IDFTN) block transforms the data sequence into time domain (note that N is usually 256 or larger). Following the IDFT block, a cyclic extension of some time length TG, chosen to be larger than the expected delay unfold, is inserted to avoid inter-symbol and inter-carrier interferences. The D/A converter contains low-pass filters with metric 1/TS, where TS is that the sampling interval.

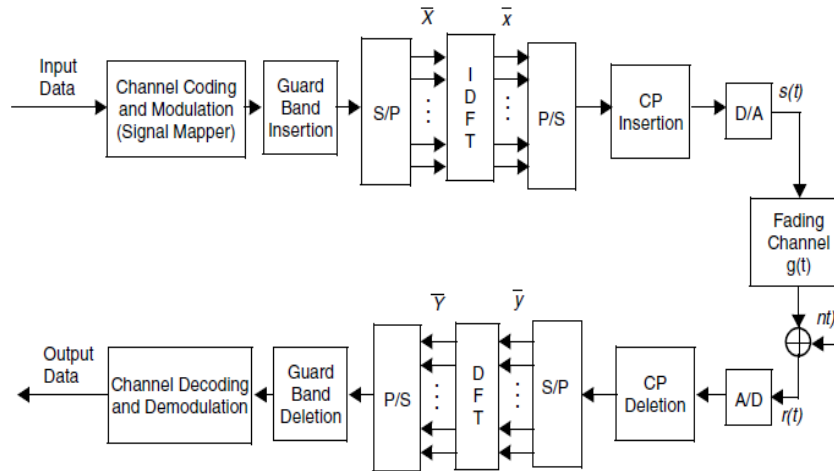

Fig. 1: Block Diagram of A Baseband OFDM System

The channel is shapely as Associate in Nursing impulse response $g(t)$ followed by the complicated additive white mathematician noise (AWGN) $n(t)$, wherever am could be a complicated values and $0 \leq \tau_m T_S \leq T_G$.

$$g(t) = \sum_{m=1}^M \alpha_m \delta(t - \tau_m T_S) \quad (1)$$

At the receiver, when passing through the digitizer (ADC) and removing the CP, the DFTN is employed to rework the info back to frequency domain. Lastly, the binary information data is obtained back after the demodulation and channel decoding.

Let $\bar{X} = [X_k]^T$ and $\bar{Y} = [Y_k]^T$ where $k=0,1,2,\dots,(N-1)$ denote the input data of IDFT block at the transmitter and the output data of DFT block at the receiver, respectively. Let $\bar{g} = [g_n]^T$ and $\bar{n} = [n_n]^T$ where $n=0,1,2,\dots,(N-1)$ denote the sampled channel impulse response and AWGN, respectively. Define the input matrix $\underline{X} = \text{diag}(\bar{X})$ and the DFT-matrix,

$$\underline{F} = \begin{pmatrix} W_N^{00} & \dots & W_N^{0(N-1)} \\ W_N^{(N-1)0} & \dots & W_N^{(N-1)(N-1)} \\ \vdots & & \vdots \end{pmatrix}$$

Where,

$$W_N^{i,k} = \left(\frac{1}{N}\right)^{-j2\pi\left(\frac{ik}{N}\right)}$$

Also Defined

$$\bar{H} = \text{DFT}_N(\bar{g})\underline{F} \bar{g} \ \& \ \bar{N} = \underline{F}\bar{n}$$

Under the assumption that the interference are completely Eliminated. You can derive:

$$\begin{aligned} \bar{Y} &= \text{DFT}_N(\text{IDFT}_N(\bar{X}) \otimes \bar{g} + \bar{n}) \\ &= \underline{X}\underline{F}\bar{g} + \bar{N} \end{aligned}$$

$$= \underline{X}\overline{H} + \overline{N}$$

This equation demonstrates that an OFDM system is equivalent to a transmission of data over a set of parallel channels.

As a result, the attenuation channel of the OFDM system will be viewed as a 2nd lattice in a very time-frequency plane, that is sampled at pilot positions and therefore the channel characteristics between pilots area unitcalculable by interpolation. The art in coming up with channel estimators is to unravel this downside with a decent trade-off between quality and performance.

The two basic 1D channel estimations in OFDM systems are illustrated in Figure II. The first one, block-type pilot channel estimation, is developed beneath the idea of slow fading channel, and it's performed by inserting pilot tones into all subcarriers of OFDM symbols within a selected amount. The other, comb-type pilot channel estimation, is introduced to satisfy the requirement for equalizing once the channel changes even from one OFDM block to future one. it's so performed by inserting pilot tones into certain subcarriers of every OFDM symbol, where the interpolation is required to estimate the conditions of information subcarriers. The ways of those 2 basic sorts square measure analyzed within the next sections.

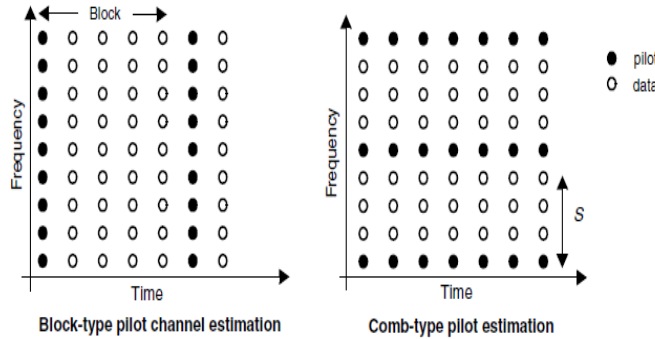

Fig. II: Two Basic Types of Pilot Arrangement for OFDM Channel Estimations

III. BLOCK BASED PILOT CHANNEL ESTIMATION

In block-type pilot-based channel estimation, as shown in Figure II, OFDM channel estimation symbols are transmitted sporadically, and every one subcarriers are used as pilots. The task here is to estimate the channel conditions (specified by \overline{H} or \overline{g}) given the pilot signals (specified by matrix by \underline{X} or vector \overline{X}) and received signals (specified by \overline{Y}), with or while not mistreatment bound data of the channel statistics. The receiver uses the calculable channel conditions to decode the received knowledge within the block till succeeding pilot symbol arrives. The estimation can be based on least square (LS), minimum meansquare error (MMSE), and modified MMSE.

A. LS Estimator

The LS estimator minimizes the parameter $(\overline{Y} - \underline{X}\overline{H})^H (\overline{Y} - \underline{X}\overline{H})$ Where $(\dots)^H$ means the conjugate transpose operation. It is shown that the LS Estimator of \overline{H} is given by [2].

$$\hat{H}_{LS} = \underline{X}^{-1} \overline{H}$$

$$= [(X_k / Y_k)]^T \quad (k = 0, 1, \dots, N-1)$$

Without using any knowledge of the statistics of the channels, the LS Estimators are calculated with very low complexity, but they suffer from a high mean square error.

B. MMSE Estimator

The MMSE estimator employs the second-order statistics of the channel conditions to reduce the mean-square error.

Denote by \underline{R}_{gg} , \underline{R}_{HH} and \underline{R}_{YV} the auto-covariance matrix of \overline{g} , \overline{H} and \overline{Y} , respectively, and by \underline{R}_{gY} the cross variance matrix between \overline{g} and \overline{H} . Also denote by σ_N^2 the noise variance $E\{|\overline{N}|^2\}$. Assume the channel vector \overline{g} and the noise \overline{N} are uncorrelated, it is derived that

$$\underline{R}_{HH} = E\{\overline{H} \overline{H}^H\} = E\{(\underline{F}\overline{g})(\underline{F}\overline{g})^H\} = \underline{F}\underline{R}_{gg}\underline{F}^H \dots(5)$$

$$\underline{R}_{gY} = E\{\overline{g} \overline{Y}^H\} = E\{\overline{g}(\underline{X}\underline{F}\overline{g} + \overline{N})^H\} = \underline{R}_{gg}\underline{F}^H \underline{X}^H \dots(6)$$

$$\underline{R}_{YY} = E\{\overline{Y}\overline{Y}^H\} = \underline{X}\underline{F}\underline{R}_{gg}\underline{F}^H\underline{X}^H + \sigma_N^2\underline{I}_N \dots\dots\dots(7)$$

Assume \underline{R}_{gg} (thus \underline{R}_{HH}) and σ_N^2 are known at the receiver in advance. The MMSE Estimator of \overline{g} is given by $\hat{g}_{MMSE} = \underline{R}_{gY}\underline{R}_{YY}^{-1}\overline{Y}^{HH}$ [2-5]. Note that if \overline{g} is not gaussian is not necessarily a mean square error estimator, but it is still the best linear estimator in the mean square error sense. At last it is calculated that

$$\begin{aligned} \hat{H}_{MMSE} &= \underline{F}\hat{g}_{MMSE} = \underline{F}[(\underline{F}^H\underline{X}^H)^{-1}\underline{R}_{gg}^{-1}\sigma_N^2 + \underline{X}\underline{F}]^{-1}\overline{Y} \\ &= \underline{F}\underline{R}_{gg}[(\underline{F}^H\underline{X}^H\underline{X}\underline{F})^{-1}\sigma_N^2 + \underline{R}_{gg}]^{-1}\hat{H}_{LS} \dots\dots\dots(8) \end{aligned}$$

IV. SIMULATION RESULTS

In general, the 2nd channel estimation schemes beat the 1D schemes by exploiting the 2nd correlations at the expense of higher process complexness and bigger time delay. Also, the block-type pilot channel estimation schemes area unit more appropriate for the slow attenuation channels, and also the comb-type pilot channel estimation schemes area unit additional appropriate for the middle and quick attenuation channels. additionally, block-type pilot schemes area unit used over middle or abstinence attenuation channels, the channel estimation error might vary significantly as a operate of the situation of the information blocks with relevancy the pilot block. The result is also a periodic variation of the coding error rates for various OFDM blocks. Table I show Bit Error Rate (BER) Vs Signal to noise ratio (SNR) whereas apply no channel estimation & by applying least sq. (LS), minimum mean-square error (MMSE) as table clearly indicated that LS methodology can turn out higher signal o noise magnitude relation.

Table - 1
BER Vs SNR For Diff Channel Estimation Techniques

S/No.	SNR	BER		
		Without Channel Estimation	LMMSE	LS
1	1	0.2301	0.205	0.1966
2	2	0.2268	0.1929	0.1836
3	3	0.22213	0.1853	0.1675
4	4	0.2136	0.1775	0.1584
5	5	0.2099	0.1718	0.1423
6	6	0.2095	0.1669	0.135
7	7	0.201	0.1579	0.1299
8	8	0.1994	0.1572	0.1177
9	9	0.1996	0.1524	0.1118
10	10	0.199	0.1496	0.1104
11	11	0.1974	0.1489	0.1056
12	12	0.1937	0.1469	0.1042
13	13	0.1948	0.1487	0.1039
14	14	0.1956	0.1466	0.1009
15	15	0.1966	0.1446	0.0996
16	16	0.197	0.1448	0.1

Performance Comparison between LS, LMMSE & No Channel Estimation

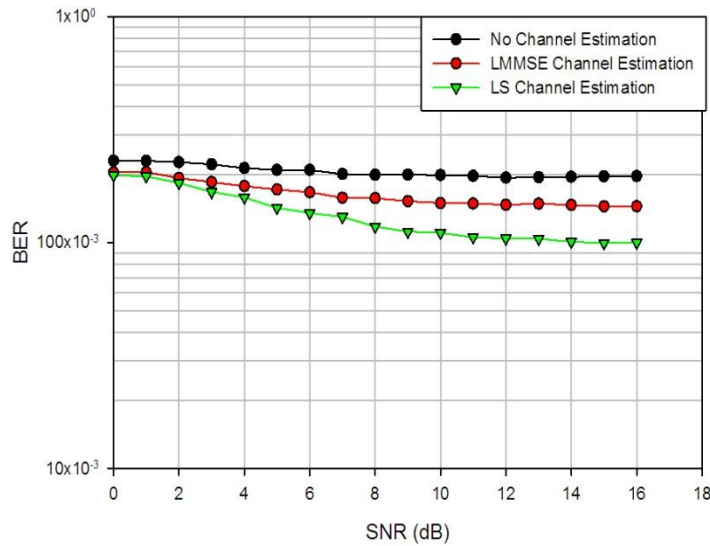

Fig. III: Show Performance of Different Block Type Channel Estimation Methods I.E. LS & LMMSE

V. CONCLUSION

In this study an occasional quality structure of receiver was proposed in order that the LS technique and linear interpolation were used for initial channel estimation. For rising accuracy of channel estimation, LMS repetitive formula was further to receiver that includes a feedback of output and improves the BER performance of system, closed to the best channel performance.

REFERENCES

- [1] D.B.Bhojar, Vaishali B. Niranjane "Channel Estimation for MIMO-OFDM Systems" Vol. 2, Issue 1, Jan-Feb 2012, pp.044-050
- [2] Manwinder Singh, Maninder Singh and Anudeep Goraya, "Block based Channel Estimation Algorithms for OFDMIEEE 802.16e (Mobile WiMAX) System" *Volume 13– No.3, January 2011.*
- [3] M. A. Ahmed, S. A. Jimaa, and I.Y. Abualhaol "Enhanced Channel Estimation Technique in MIMO-OFDM System" 2012 third international workshop on the performance enhancements in MIMO OFDM System.
- [4] Guan Gui, Wei Peng and Fumiyuki Adachi, "Improved Adaptive Sparse Channel Estimation Based on the Least Mean Square Algorithm" 2013 IEEE Wireless communications and networking conference (WCNC) PHY.
- [5] K. Vidhya and Dr.K.R.Shankar kumar, "PILOT BASED CHANNEL ESTIMATION FOR MIMO- OFDM SYSTEMS" IRACST – International Journal of Computer Networks and Wireless Communications (IJCNC), ISSN: 2250-3501 Vol.3, No2, April 2013.
- [6] Srishtansh Pathak and Himanshu Sharma, "Channel Estimation in OFDM Systems" Volume 3, Issue 3, March 2013, ISSN: 2277 128X.
- [7] Sinem Coleri, Mustafa Ergen, Anuj Puri, and Ahmad Bahai "Channel Estimation Techniques Based on Pilot Arrangement in OFDM Systems" IEEE TRANSACTIONS ON BROADCASTING, VOL. 48, NO. 3, SEPTEMBER 2002.
- [8] Ali Asadi and Behzad Mozaffari Tazehkand, "A New Method to Channel Estimation in OFDM Systems Based on Wavelet Transform" International Journal of Digital Information and Wireless Communications (IJDWC) 3(1): 1-9 The Society of Digital Information and Wireless Communications, 2013 (ISSN: 2225-658X)