

# Digital Shoes to Guide Blind People with Measurement of Calorie Burning

**Karthik. A**

*Department of Electronics & Communication Engineering  
Student  
Sri Eshwar College of Engineering*

**Nivetha. P**

*Department of Electronics & Communication Engineering  
Student  
Sri Eshwar College of Engineering*

**RajaIyyappan. S**

*Department of Electronics & Communication Engineering  
Student  
Sri Eshwar College of Engineering*

**Ranjitha. R**

*Department of Electronics & Communication Engineering  
Student  
Sri Eshwar College of Engineering*

**Arun Kumar. G. S**

*Assistant Professor  
Department of Electronics & Communication Engineering  
Sri Eshwar College of Engineering*

## Abstract

In order to calculate the walking distance there is a need of a device. The distance is displayed in meter as well as kilometer in mobile phone using Bluetooth technology. The calorie burned while walking is based on the weight and amount of time he/she walks. We are also going to display the calorie burned every day in the mobile. Here we attached a force sensitive resistor (FSR) in sole of the shoe. When a person walks, he/she used to press his/her foot in the land. The FSR senses it and starts counting the steps which is also displayed in the mobile. It is not only great for health monitoring, but also used to guide blind people. The proposed system is that it utilizes an embedded vision system of three simple IR sensors and brings together all reflective signals in order to codify an obstacle through PIC microcontroller. It is a simple, cheap, friendly user; smart blind guidance system is designed and implemented to improve the mobility of both blind and visually impaired people in a specific area.

**Keywords: Voice Recognition, FSR, IR sensor, Mobile Phone, Calorie Measurement, Distance calculation**

## I. INTRODUCTION

Many people suffer from serious visual impairments preventing them from travelling independently. Accordingly, they need to use a wide range of tools and techniques to help them in their mobility. One of these techniques is orientation and mobility specialist who helps the visually impaired and blind people and trains them to move on their own independently and safely depending on their other remaining senses. Information about the object characteristics can create additional knowledge to enhance space manifestation and memory of the blind. To overcome the above-mentioned limitations, this work offers a simple, efficient, configurable electronic guidance system for the blind and visually impaired persons to help them in their mobility regardless of where they are, outdoor or indoor. The originality of the proposed system is that it utilizes an embedded vision system of three simple IR sensors and brings together all reflective signals in order to codify an obstacle through PIC microcontroller. Hence, in addition to distance the proposed guidance system enables the determination of two main characteristics of the obstacle which are material and shape. Furthermore, the user of the system does not need to carry a cane or other marked tool. He/she can just wear a shoe just like others. It has high immunity to ambient light and color of object and it is very suitable for real-time applications. The shoes apply haptic feedback to guide the wearer at the right turn to meet up with friends or to get wherever they need to be. The main component of this system is the infrared sensor which is used to scan a predetermined area around blind by emitting-reflecting waves. The reflected signals received from the barrier objects are used as inputs to PIC microcontroller. The microcontroller is then used to determine the direction and distance of the objects around the blind. It also controls the peripheral components that alert the user about obstacle's shape, material, and direction. The implemented system is cheap, fast, and easy to use and an innovative affordable solution to blind and visually impaired people in third world countries.

## II. LITERATURE SURVEY

Blindness is a state of lacking the visual perception due to physiological or neurological factors. The partial blindness represents the lack of integration in the growth of the optic nerve or visual center of the eye, and total blindness is the full absence of the visual light perception. In this proposed work, a simple, cheap, friendly user, virtual eye will be designed and implemented to improve the mobility of both blind and visually impaired people in a specific area. The proposed work includes a wearable

equipment consists of head hat, mini hand stick and foot shoes to help the blind person to navigate alone obstacles that may be encountered, whether fixed or mobile, to prevent any possible accident. The main component of this system is the ultrasonic sensor which is used to scan a predetermined area around blind by emitting-reflecting waves. The reflected signals received from the barrier objects are used as inputs to Arduino microcontroller. The microcontroller carry out the issued commands and then communicate the status of a given appliance or device back to the earphones using Raspberry pi speech synthesizer. The proposed system is cheap, fast, and easy to use and an innovative affordable solution to blind and visually impaired people in third world countries [1]. The obesity epidemic represents a growing societal concern. One challenge in weight control is the difficulty of tracking food calories consumed and calories expended by activity. This paper presents a system for automatic monitoring of calories expended using a single body-worn accelerometer. Our system uses activity inference combined with signal analysis to estimate calories expended in real time using regression formulas developed by the American College of Sports Medicine. To validate our system, we have collected data from 51 subjects in a laboratory setting using a treadmill and a more natural field test. Actual caloric expenditure was determined using the medical “gold standard” measurement, of oxygen consumption. We are able to achieve 89% accuracy with lab data and 79% with field data – both high enough to be useful in practice [2]. This system presents the overall framework of the necessity as a safety monitor for Alzheimer’s patients. Alzheimer’s patient is a person having the difficulties about memory with the concepts of place & time. Global Positioning System (GPS) locator watches for patients are essentially RT-trackers that allow the family members or caregivers to have a complete access to whereabouts of person 24hrs. The GPS technology is placed inside a cavity made from a polycarbonate material which is in the midsole of the shoe. GTX says, the normal duration of the shoe - one to three years. The design of the system gives Energy efficiency, robustness, and reliability. Patient is having a mobile sensor unit which includes a GPS chip and antennas. Mobile sends latitude, longitude, and a time stamp. A GTX tracking map gives the latitude and longitude information on a geographical information system (GIS). The developed system can be used to track a specific area of patients. The main advantage of the system is a multilingual system. This means that we store the wav file in any language and play it back [3]. This paper describes an efficient methodology for aiding the blind and the visually impaired in their navigation. Track manager is basically a pair of shoes along with a remote control, and an ear phone. It works in two modes in a domestic environment. a) Track recorder mode in which the track manager records the track initially and guides the blind from the next time with voice output. Recording tracks involves 2 parameters: number of steps taken and the direction. The former is calculated with the help of a footswitch and the latter is found using a digital compass. These devices are connected to the microcontroller fitted in the shoes b) Staircase mode which helps the user to find the location of staircase and climb up or down the stairs easily. It employs an obstacle detection unit using infrared sensors. Traffic mode: In this mode only the obstacles detection system is activated [4]. This paper presents the development of an iShoes system for blind and visually impaired people. The iShoes system utilizes a microcontroller with sound output interfaced with ultrasonic sensors. The prototype system is designed to be specifically mounted on/in the shoes to aid navigation in urban routes. The ultrasonic transducers determine the range from an obstacle and then play an audio message to reflect the distance from the target. This system will assist blind and visually impaired people in navigating a path through an unfamiliar environment [5]

### III. PROPOSED DIGITAL SHOES

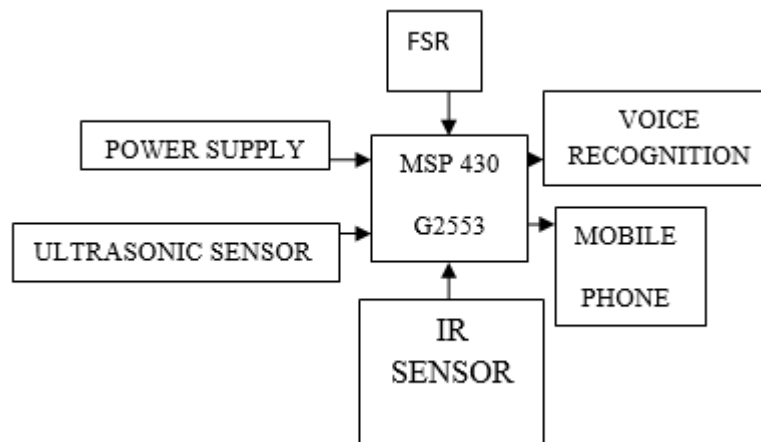

Fig. 1: Block Diagram of Digital Shoe

Power supply is given to the microcontroller, by pressing the foot the force will act on the force sensitive resistor (FSR) which is fixed in the sole of the shoe. The change in resistance is used to generate clock pulse. The clock pulse is given to the specific light sensor to detect a select light wavelength in the Infra-Red (IR) spectrum. By using an LED which produces light at the same wavelength as what the sensor is looking for, you can look at the intensity of the received light. When an object is close to the sensor, the light from the LED bounces off the object and into the light sensor. This results in a large jump in the intensity, which we already know can be detected using a threshold. In Ultrasonic sensor, the sonic waves emitted by the transducer are reflected by an object and received back in the transducer. After having emitted the sound waves, the ultrasonic sensor will switch to receive

mode. The time elapsed between emitting and receiving is proportional to the distance of the object from the sensor. These two sensors are connected to the microcontroller based on the results given by these Sensors; Voice recognition system will be activated by the microcontroller to guide the blind.

#### **IV. CONCLUSION**

Proposed system implementation presents the overall framework of the necessity of positioning system as a safety monitor for Alzheimer's patients. It is easy to find and guide the patient by sitting on the place. We can apply the system for the child for safety and perfect guidance.

#### **REFERENCES**

- [1] Darren quick-comport shoes with embedded GPS to track of Alzheimer's Patients.
- [2] Andrea sciarrone-context and location awareness indoor security and e-health applications.