

Pure Sine Wave Inverter Design for Street Light Emergency Backup System

Md. Humayun Kabir Khan

Assistant Professor

*Department of Electrical and Electronic Engineering
City University, Dhaka-1216, Bangladesh*

Salah Uddin

Lecturer

*Department of Electrical and Electronic Engineering
Feni University, Feni-3900, Bangladesh*

Md. Moklesur Rahman

Lecturer(34th BCS General Education)

*Department of Physics
Shahzadpur Govt. College, Shahzadpur, Sirajganj,
Bangladesh*

Md Abdullah Al Rakib

Lecturer

*Department of Electrical and Electronic Engineering
City University, Dhaka-1216,
Bangladesh*

Abstract

Pure sine wave inverters produce power that equivalents to or better than the power in the home. It utilizes refined innovation to secure even the most delicate hardware. The main objective of this research is to plan and actualize a single-phase inverter that can change DC voltage over to AC voltage at high effectiveness and ease. Sun-oriented and wind-fueled power age is being supported these days as the world progressively centers around ecological concerns. Power inverters, which convert sun-oriented cell DC into homegrown use AC, are one of the critical advancements for conveying effective AC power. To convey such execution, the power inverters are driven by high-performance PIC 16F877A microcontroller units (MCUs) that can accomplish significant level inverter control and thusly this microcontroller is the core of the system and controls the whole system. The microcontroller is modified utilizing an implanted C compiler and in explicit CCS C to create sine pulse width regulated (SPWM) pulses which are utilized to drive H-bridge. By substitute exchanging switches of two pins of H-connect rotating 12V DC voltage is changed over into 240V AC voltage. To assemble the plan, it is first mathematically displayed and then it is simulated in Proteus lastly and the outcomes are essentially confirmed.

Keywords: Pure sine wave, Field-effect transistor, MOSFET, LC low pass filter, Inverter, Dark dawn

I. INTRODUCTION

Electronics are more basic to our day by day lives than any other time in recent memory. We depend on our PCs and TVs for gaming and diversion and our cell phones for essentially everything else, similar to moment data, in a hurry route, and ordinary correspondence. On top of these basic gadgets, other costly pieces range from gaming consoles to brilliant home apparatuses to even the kitchen microwave. Pure sine wave inverters are an incredible method to deal with the entirety of your tech gadgets by making consistent power flow. More than a standard flood defender, pure sine wave inverters keep your AC-controlled gear liberated from any possible harm by guaranteeing a consistent current that doesn't surge or fade. Normally, for something so significant, It is needed to pick the absolute best choice available [1].

A pure sine wave inverter's essential occupation is to change over DC (direct current) power from either sun oriented boards or a battery bank into usable AC (substituting current) power. To do this, it takes constant DC and changes it into a pure sine wave curve that sways easily and consistently above and under zero volts. This strategy for conveying AC power is spotless enough to control touchy gadgets that require a consistent contribution to work effectively [5].

Pure sine inverters chip away at a couple of cycles that are: The inverter delivers a progression of oscillating pulses that go through a semiconductor circuit, called an IC circuit. These motions produce voltage tops through another battery accuse of both positive and negative poles. When the peaks arrive at a particular frequency, they can be moved to the inverter's amplifier.

The oscillating pulses are enhanced or helped to accomplish a more raised level of current. This level of current is important to control your machines or gadgets. To do this, the inverter applies the intensified voltage to the yield transformer's secondary winding. Low-level AC power that was gotten from the amplifier goes through the secondary windings of the transformer and is stepped up to a voltage that is adequate to control the gadgets and apparatuses [2].

Altered sine waves are rough, and their voltage rises and falls unexpectedly. Phase angles are more honed and less uniform, causing a more unpleasant, less unsurprising conveyance of voltage. Changes between extremities at the zero-voltage line aren't quick, however, set aside some effort to happen, leaving holes in the conveyance of capacity to gadgets and machines.

II. DESIGN OF PURE SINE WAVE INVERTER

Pure sine wave power inverters produce amazingly perfect, dependable, power as we would regularly get from our service organization. A few things must be run off of a pure sine inverter, else, it may not run how the producer planned that gadget to run. A few instances of utilizations that should be run off of a pure sine wave inverter are microwaves, key machines, breathing machines, CPAP machines, laser printers, computerized timekeepers, delicate gadgets. PSW power inverters likewise permit motors to run cooler contrasted with a non-unadulterated sine (altered sine wave or MSW) and start simpler also [3].

These days, there are a developing number of individuals utilizing a pure sine wave inverter. A power inverter is an electronic gadget or hardware that changes direct current (DC) to alternating current (AC). The information voltage, frequency, and output voltage, and generally speaking force taking care of relying upon the plan of the particular gadget or hardware. It permits having a dependable wellspring of power for different machines regardless of whether they are off the power grid. The method of activity of an inverter is partitioned into three phases: oscillator, amplifier, and output transformer stage [4].

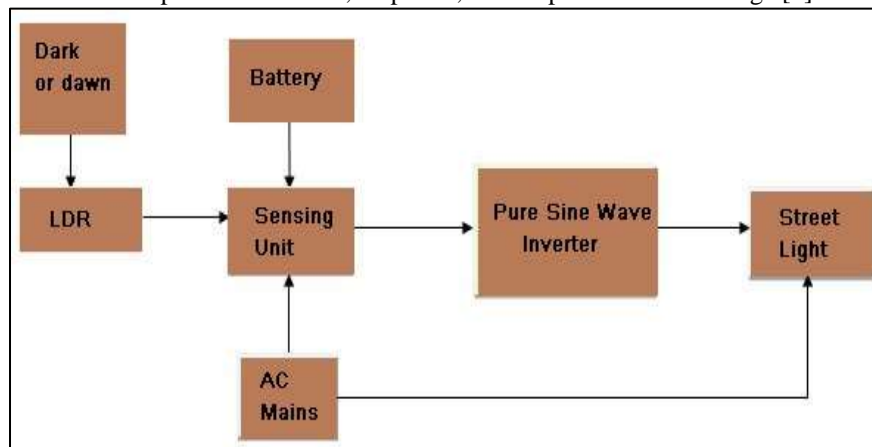

Fig. 1: Block diagram of a pure sine wave inverter system.

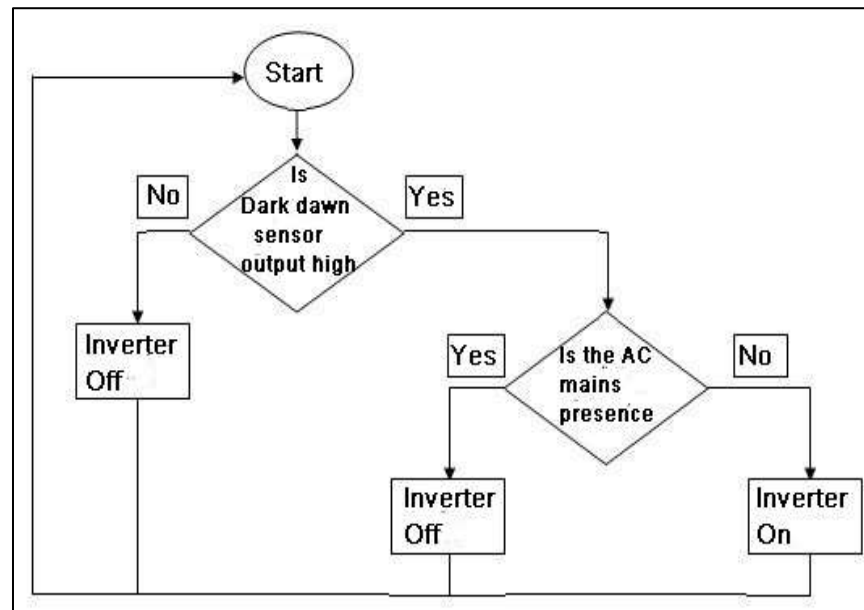

Fig. 2: System Block and Flow Chart Diagram.

Pure Sine Wave Inverter is a larger part coordinated by a MOS field-effect transistor and an ordinary power transformer. The output power relies upon the MOS field-effect transistor and a power transformer. It is appropriate for beginner makings of electron fans, for it can stay away from complex transformer winding. The accompanying article will acquaint us with the working standard and making the cycle of the inverter [6].

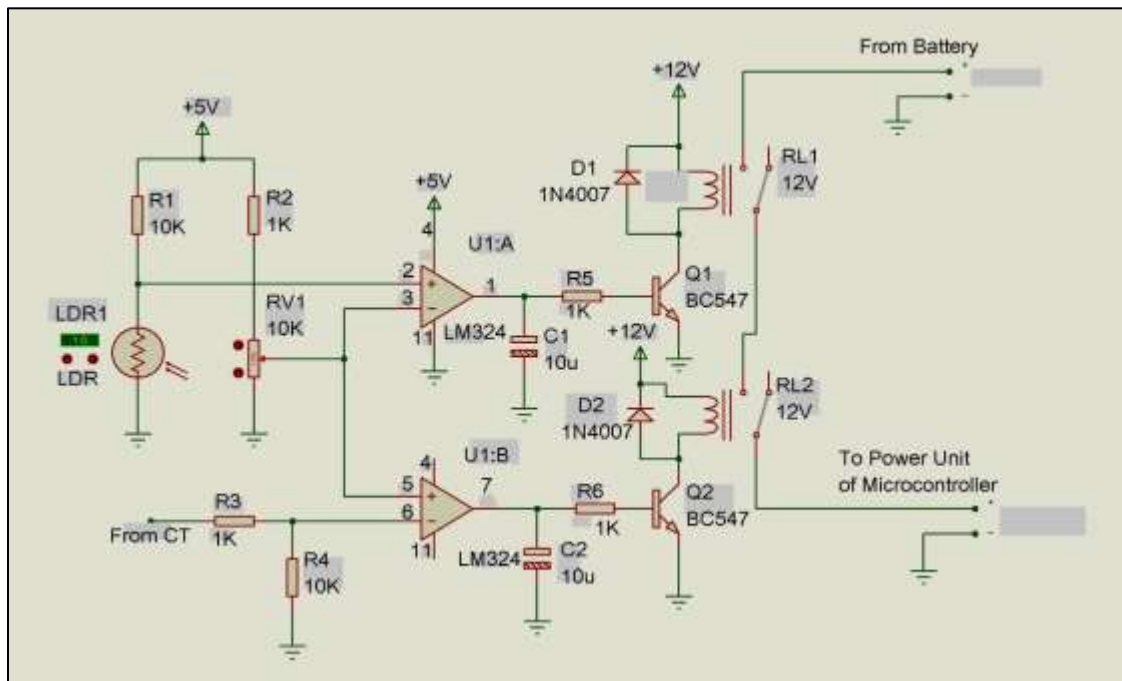

Fig. 3: Dark-Dawn and Main Power Failure Detector Circuit.

As appeared in Fig. 3, the principal pin of the LDR is associated with the operation amp "U1: A" non-transforming terminal. At the point when light falls on the LDR, its opposition diminishes. The output "U1: A" will be lower when the non-reversing terminal voltage is lower than the transforming terminal voltage. Therefore, transfer RL1 will be deactivated. In a dim circumstance, the LDR obstruction turns out to be high. The "U1: A" output will be higher when the non-transforming terminal voltage is higher than the inverting terminal voltage. Accordingly, hand-off RL1 will be actuated.

Also, the operation amp "U1: B" altering terminal voltage will be higher than the non-reversing terminal voltage when the AC fundamental is available, so the "U1: B" output will be lower. Thus hand-off, RL2 will be deactivated. Something else, hand-off RL2 will be initiated if AC mains come up short [7]. As a rule, it is expected to utilize MOSFETs designed as high-side switches. Commonly It is needed to utilize MOSFETs designed as high-side and low-side switches, For example, in bridge circuits. In half-bridge circuits, it has 1 high-side MOSFET and 1 low-side MOSFET. In full-bridge circuits, it has 2 high-side MOSFETs and 2 low-side MOSFETs. In such circumstances, there is a need to utilize high-side circuitry close to low-side drive hardware.



Fig. 4: (a) Sine wave Inverter Circuit Overview (b) Dark down and Power Circuit Overview.

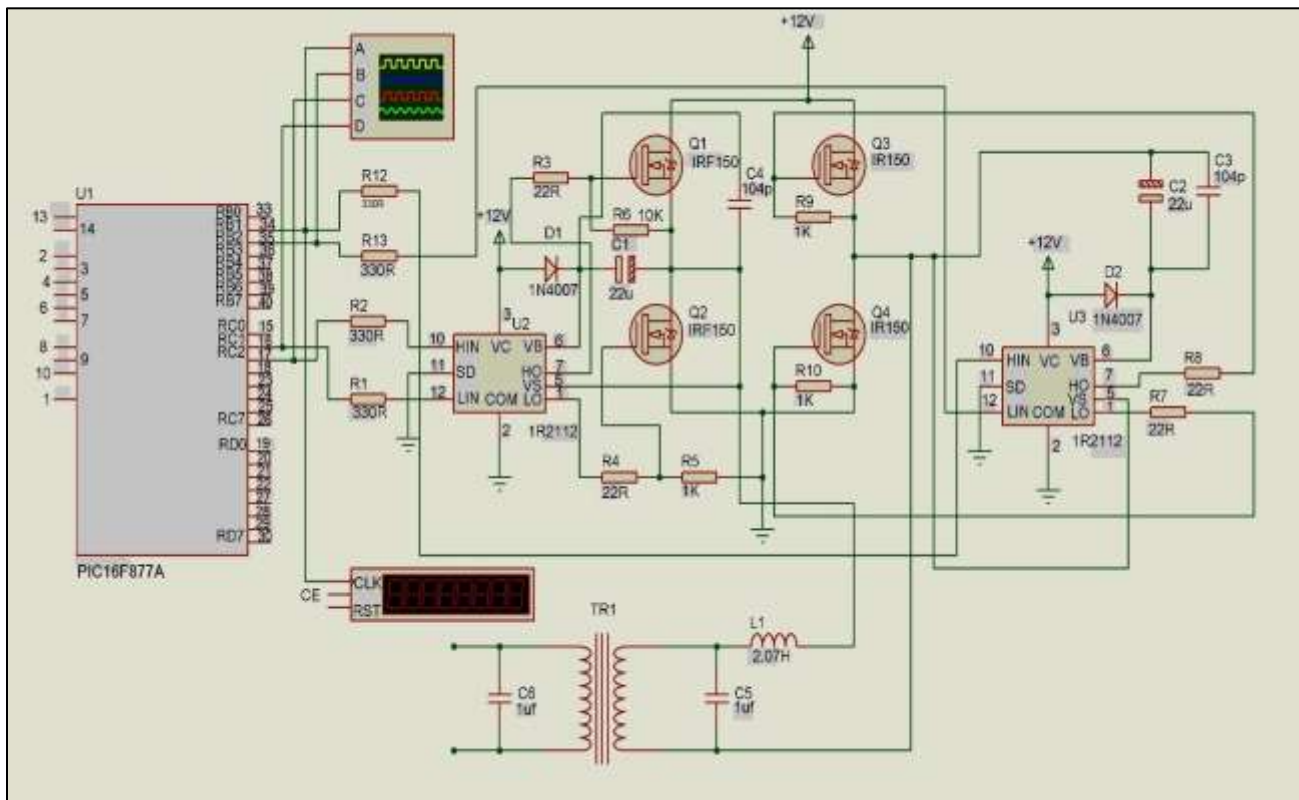

Fig. 5: IR2112 Circuit for High -voltage Full-bridge Drive with Independent Switch Control.

A 12V dc from the battery was taken care of to the microcontroller through a 5V steady controller with ac channel capacitors at both the info and output sides. The capacitor esteems were gotten from the LM7805 controller datasheet. The microcontroller was timed with an outside clock of 20MHz which was grounded utilizing capacitors whose qualities were gotten from the PIC16F877A datasheet. The High PWM and Square wave outputs were acquired from pins CCP1 and RB1 while Low PWM and Square wave were gotten from pin CCP2 and RB2 separately. The microcontroller outputs were utilized to control the MOSFETs Full H-Bridge however MOSFET drivers U2 and U3 whose pins association were done as appeared in IR2112 datasheet [8].

C6 and C8 are settling capacitors that channel all the air conditioner flows. C1 and C2 are bootstrap capacitors whose qualities were determined in the plan. They are charged through diodes D1 and D2. The outputs of the MOSFET drivers were taken care of to the MOSFET doors through resistors R3, R4, R7 and R8 which controlled the MOSFET exchanging speed. Resistors R5, R6, R9, and R10 were utilized for releasing the capacitance CGS to consider legitimate MOSFET exchanging. The H-Bridge was controlled by a 12V dc from the battery and the output was acquired between the outputs Q1-Q2 and Q3-Q4. The H-Bridge yield was taken care of to an LC low pass channel. The estimations of the inductor L1 and Capacitor C5 were as determined in the plan [9].

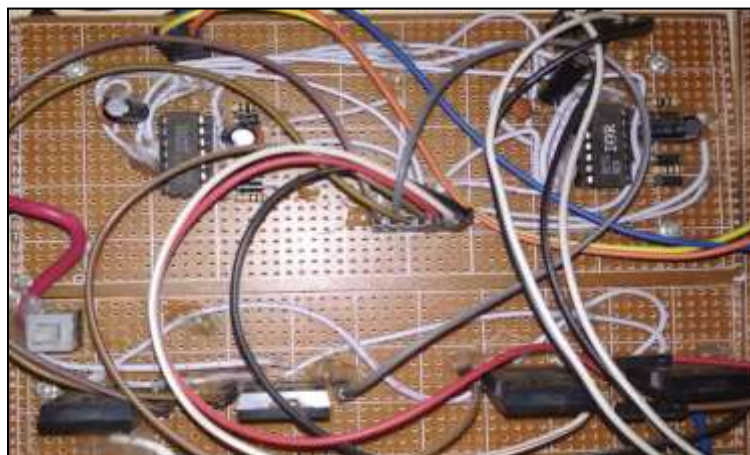

Fig. 6: H-Bridge with IGBT gate Driver Circuit.

The output of the Filter was supported by utilizing a Step-up Transformer with a change proportion of 18.3. A capacitor C6 was put at the output to channel the sounds. In a dim circumstance when AC principle flops then PIC16F877A based SPWM signal generator circuit and H-connect network were associated with the battery through transfer RL1 and RL2 of the Dark-sunrise and

Main force disappointment discovery circuit. Therefore, we have gotten the ideal level sine wave output from the executed inverter. The pulses that are provided at MOSFETs' doors and the output sifted waveform. The simulation results show that the output of the H-Bridge inverter is being sifted to a degree where the pure sinusoid waveform is gotten [10].

III. SIMULATION AND EXPERIMENTAL RESULTS

Simulation-based two different output voltages from pins RB1 and RB2 of PIC16f877A are shown in fig. 9.

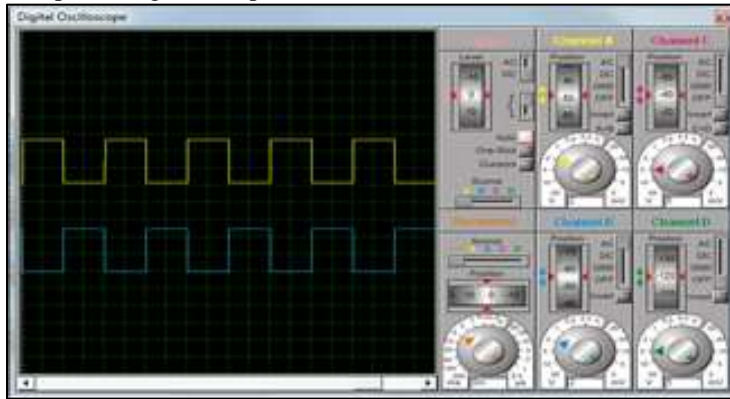

Fig. 7: Simulated Square Wave Outputs (50Hz) from Pins RB1 and RB2 of PIC16f877A



Fig. 8: Obtained Square Wave Output from Pin RB1 of PIC16f877A

Fig. 8 shows a square wave hardware-based simulation of output voltage from pin RB1 of PIC16f877A. The equivalent has been seen in the useful acknowledgment of the inverter, that is, the waveform at the output of H-Bridge isn't pure sinusoidal indeed an alternate wave is acquired from connecting output. This waveform is then transformed into a pure sinusoidal waveform utilizing the filter.

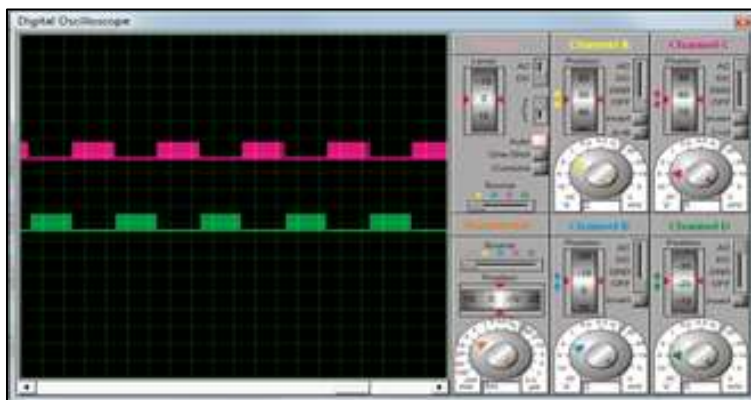

Fig. 9: Simulated SPWM Outputs (5 kHz) from Pins RC1 and RC2 of PIC16f877A

Fig. 7 shows the PWM output waveform of the H-connect inverter that is later changed over to a pure sine wave by utilizing an uninvolved low-pass L-C filter, which dispenses with the harmonic segments of the output waveform and produces a pure sine wave.



Fig. 10: Obtained SPWM Output from Pin RC1 of PIC16f877A

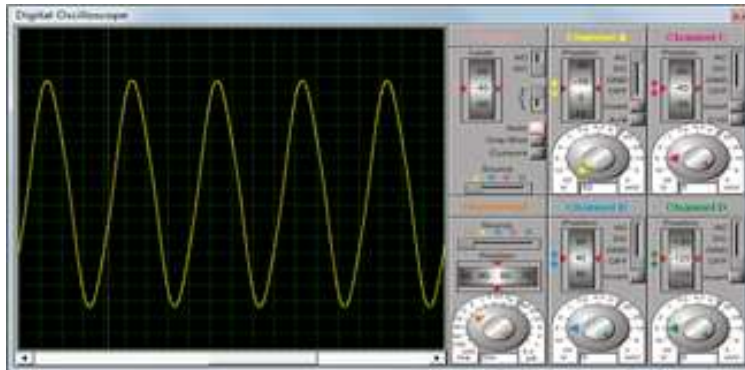

Fig. 11: Simulated Sine wave Inverter Output without Load

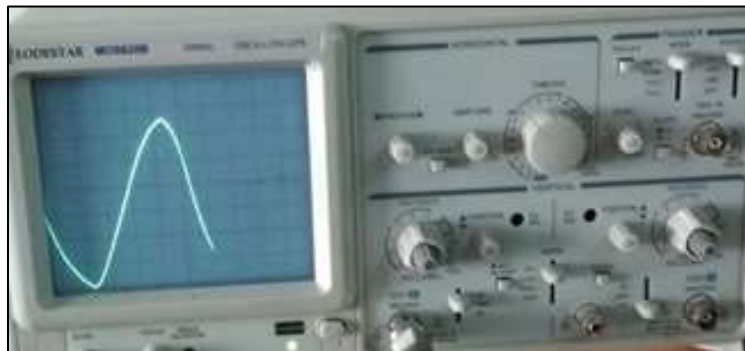

Fig. 12: Obtained Sine wave Inverter Output without Load

After filtering, we obtained 215V (RMS), 50Hz pure sine wave output voltage waveform as shown in Fig. 12. In light of the simulation result, a model of the proposed inverter system has been constructed and tried in the lab for approval. Fig. 12 shows the sine wave output voltage across the resistive load. The recurrence of the sinusoidal waveform was discovered to be 50Hz as grid standard in Bangladesh.

IV. CONCLUSION

Energy emergencies are of uncommon consideration in this day and age. The ceaseless use of non-sustainable power sources will stop the restricted assets in not so distant future. To save the assets, a few option sustainable sources have been being used nowadays. The power generated from sustainable sources, as sun-based energy, produces is a DC power which can be put away in batteries. This DC power should be changed over to AC power as a large portion of the machines utilized in our day by day life is reliant on AC power [11].

To defeat this deterrent, DC-AC Inverter took birth. Inverters can be classified into three groups: Square wave, adjusted sine wave, and pure sine wave. Considering power wattage, efficiency, and harmonic substance, pure sine wave inverters have been demonstrated to have the best quality among the three sorts. The control circuit for pure sine wave inverter produces sinusoidal pulse width modulation. There are two essential geographies to create pulse width modulation, a simple Control circuit, and a microcontroller-based control circuit.

In this paper, the presentation of the two geographies utilized in inverters has been analyzed and a DC-AC pure sine wave Inverter utilizing the Analog control circuit has been executed [12].

REFERENCES

- [1] Md. Manirul Islam, M.M. Rana, Abu Farzan Mitul, Md Manirul Alam Khan., " Microcontroller based power inverter for grid-connected PV system.," 2012 International Conference on : Green and Ubiquitous Technology (GUT), DOI: 10.1109/GUT.2012.6344185.
- [2] 'The Best Pure Sine Wave Inverters (Review & Buying Guide) in 2020', by Acton Media Inc [Online] Available: <https://www.thedrive.com/reviews/36434/pure-sine-wave-inverter-2> [Accessed: 03- December- 2020].
- [3] 'Pure Sine Wave Power Inverters' by Inverters R Us Corp [Online]. Available: <https://invertersrus.com/product-category/power-inverters /pure-sine-wave/>. [Accessed: 03- December- 2020].
- [4] Meraj Hasan, Junaid Maqsood, Mirza Qutab Baig, Syed Murtaza Ali Shah Bukhari, Salman Ahmed, "Design & Implementation of Single Phase Pure Sine Wave Inverter Using Multivibrator IC," 2015 17th UKSIM-AMSS International Conference on Modelling and Simulation, doi: 10.1109/UKSim.2015.58.
- [5] S. Sarwar, S. Aslam, W. Arsalan, M. U. Sajjad, A. A. Khan and O. Shami, "Design and Real-Time Implementation of Transformer-less Pure Sine-Wave Inverter," 2020 International Conference on Engineering and Emerging Technologies (ICEET), Lahore, Pakistan, 2020, pp. 1-6, doi: 10.1109/ICEET48479.2020.9048200.
- [6] M. B. Gulame, O. K. Kelkar, S. S. Thopate, C. Maloji Gadre and R. D. Kedari, "DESIGN OF SOLAR BASED PURE SINE WAVE INVERTER," 2018 Second International Conference on Computing Methodologies and Communication (ICCMC), Erode, 2018, pp. 924-927, doi: 10.1109/ICCMC.2018.8487929.
- [7] 'What is a pure sine wave inverter' by medium [online]. Available: [https:// https://medium.com/@alphazee17/what-is-a-pure-sine-wave-inverter-116d01372e24](https://medium.com/@alphazee17/what-is-a-pure-sine-wave-inverter-116d01372e24). [Accessed: 03- December- 2020].
- [8] 'Pure Sine Wave Inverter Working Principle' by PowerInverter.org [Online]. Available: [https http://www.powerinverter.org/pure-sine-wave-inverter-working-principle.html](https://www.powerinverter.org/pure-sine-wave-inverter-working-principle.html). [Accessed: 03- December- 2020].
- [9] R. Haider, R. Alam, Nafisa Binte Yousuf and K. M. Salim, "Design and construction of single phase pure sine wave inverter for photovoltaic application," 2012 International Conference on Informatics, Electronics & Vision (ICIEV), Dhaka, 2012, pp. 190-194, doi: 10.1109/ICIEV.2012.6317332.
- [10] M. B. Gulame, O. K. Kelkar, S. S. Thopate, C. Maloji Gadre and R. D. Kedari, "DESIGN OF SOLAR BASED PURE SINE WAVE INVERTER," 2018 Second International Conference on Computing Methodologies and Communication (ICCMC), Erode, 2018, pp. 924-927, doi: 10.1109/ICCMC.2018.8487929.
- [11] M. B. Cheema, S. A. Hasnain, M. M. Ahsan, M. Umer and G. Ahmad, "Comparative analysis of SPWM and square wave output filtration based pure sine wave inverters," 2015 IEEE 15th International Conference on Environment and Electrical Engineering (EEEIC), Rome, 2015, pp. 38-42, doi: 10.1109/EEEIC.2015.7165289.
- [12] M. R. Ruman, D. Paul, A. Barua, A. K. Sarker, A. Iqbal and S. Barua, "Design and Implementation of SPWM Inverter," 2019 International Conference on Computing, Communication, and Intelligent Systems (ICCCIS), Greater Noida, India, 2019, pp. 490-494, doi: 10.1109/ICCCIS48478.2019.8974542.